



GB Inspection Systems Ltd.
22A Cobbett Road
Burntwood Business Park
Burntwood, Cannock
Staffordshire, WS7 3GL. UK

T +44 (0)121 351 5025
F +44 (0)1543 279619
E enquiries@gbinspection.com
W www.gbinspection.com
Company Registration Number 3021497

GB Inspection Systems Ltd

Leading UK Designer and Manufacturer of Ultrasonic Transducers and Accessories.





Index Page

Contact Page.....	Pages 3
Single Shear Wave Transducers.....	Page 4
Twin Shear Wave Transducers	Page 5
Angle Compression Transducers	Page 6
Single Compression 0° Transducers.....	Page 7-8
Twin Compression 0° Transducers	Page 9-11
High Temperature Transducers.....	Page 12
Creep Wave & Surface Wave Transducers.....	Page 13
TOFD including LIMBOTOFD™, TULA™ & Integral-TOFD Transducers & Integral PALM™	Pages 14-17
Railway—Axle	Page 18
Railway—Track Including Network Rail Approved Transducers	Pages 19-21
Transducer Cables	Page 22
Transducer & Cable Accessories & Cases with Bespoke Foam	Page 23-24
Calibration Blocks	Page 25
Custom Made Transducers.....	Page 26
Certification	Page 27
Calibration, Service & Repair	Page 28
NDT Equipment & Consumables	Page 29
Partnerships & Global Distribution.....	Pages 30-31



Contact Page

Ways to get in touch with GB Inspection Systems Ltd

GB Inspection Systems Ltd.
22A Cobbett Road
Burntwood Business Park
Burntwood, Cannock
Staffordshire, WS7 3GL. UK

Sales Enquiries sales@gbinspection.com

Telephone +44 (0)121 351 5025

Website www.gbinspection.com

The Sales Team:

Neil Smith, Sales & Technical Support

Karen Smith, Sales Manager & Credit Control

Frankie Hall-Williams, Internal Sales

Deanna Mullen, Internal Sales

You can also find us on the following social media:

@GBInspectionSystems



@GBInspection



@gbinspection









GB Inspection
Systems Ltd

Shear Wave Transducers — Single

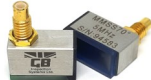
Single Shear Wave / Angle Beam direct contact transducers

- Ideal for general purpose testing of Welds, Plates, Pipes / Tubing, Castings and Forgings
- Thicker shoes available for extended life
- Contoured contact face available to match convex and concaved testing surfaces







Images	Order Code	Description	Crystal Size	Standard Angles	Standard Frequency
	SMSS	Sub Miniature Single Shear with a Contact Face of 12 x 10mm with connection of your choice	Ø6.3mm	38°, 45°, 60°, 70°	5MHz, 10MHz
	MMSS	Medium Miniature Single Shear with a Contact Face of 16 x 8mm with connection of your choice	5mm x 5mm	38°, 45°, 60°, 70°	5MHz
	MSS	Miniature Single Shear with a Contact Face of 20 x 12mm with connection of your choice	Ø6.3mm	38°, 45°, 60°, 70°	5MHz, 10MHz
	SS	Single Shear with a Contact Face of 29 x 16mm with connection of your choice	Ø10mm	38°, 45°, 60°, 70°	2MHz, 4MHz
	SSHP	Single Shear High Performance with a Contact Face of 29 x 16mm with connection of your choice	Ø10mm	38°, 45°, 60°, 70°	2MHz, 4MHz
	MWS	Single Shear with a Contact Face of 28 x 16mm with connection of your choice	8 x 9mm	38°, 45°, 60°, 70°	2MHz, 4MHz
	LSS	Large Single Shear with a Contact Face of 40 x 25mm. Versions a, b, c, d available in different crystal sizes. With connection of your choice	A-Ø15mm, B-14 x 14mm C-15 x 17mm, D-16 x 16mm	38°, 45°, 60°, 70°	(b, c, d) 2MHz, (a, c, d) 2.5MHz, (a, b, c, d) 4MHz
	XLSS	Extra Large Single Shear with a Contact Face of 50 x 32mm with connection of your choice	20 x 20mm	38°, 45°, 60°, 70°	2MHz, 2.5MHz, 4MHz

Shear Wave Transducers — Twin

Twin Shear Wave / Angle Beam direct contact transducers

- Provide improved near-surface resolution and superior signal to noise ratio especially when testing rough surfaces
- Enhanced capability for inspecting thin materials for flaws occurring directly under the surface
- Available with thick shoe for extended life
- Contoured contact face available to match convex and concaved testing surfaces









Images	Order Code	Description	Crystal Size	Standard Angles	Standard Frequency
	BTP	Boiler Tube Transducer with a Contact Face of 18 x 15mm with 2 Meter Integral Cable with connection of your choice.	5mm x 5mm	45°, 60°, 70°	5MHz, 10MHz
	TS	Twin Shear with a Contact Face of 29 x 16mm with connection of your choice	8 x 5mm	38°, 45°, 60°, 70°	2MHz, 4MHz
	MWT	Twin Shear with a Contact Face of 27 x 16mm with connection of your choice	8 x 5mm	38°, 45°, 60°, 70°	2MHz, 4MHz
	LTS	Large Twin Shear with a Contact Face of 40 x 25mm with connection of your choice	7 x 12mm	38°, 45°, 60°, 70°	2.5MHz, 4MHz

Angle Compression Transducers – Single & Twin

Angle Beam Compression Wave Transducers

- Specifically designed for inspection of coarse grained and attenuating materials such as Austenitic Stainless steel or Duplex
- Gives high signal to noise ratio when standard shear wave probes cannot be used
- Thicker shoes available for extended life
- Contoured contact face available to match convex and concaved testing surfaces









Images	Order Code	Description	Crystal Size	Standard Angles	Standard Frequency
	SAC	Single Angle Compression with a Contact Face of 29 x 16mm with connection of your choice.	Ø10mm	38°, 45°, 60°, 70°	2MHz, 4MHz
	LSAC	Large Single Angle Compression with a Contact Face of 25 x 40mm with connection of your choice.	Ø15mm	38°, 45°, 60°, 70°	2.5MHz, 4MHz
	XLSAC	Extra Large Single Angle Compression with a Contact Face of 50 x 32mm with connection of your choice.	Ø20mm	38°, 45°, 60°, 70°	2MHz, 4MHz
	TAC	Twin Angle Compression with a Contact Face of 27 x 16mm with connection of your choice.	5 x 10mm	38°, 45°, 60°, 70°	2MHz, 4MHz
	LTAC	Large Twin Angle Compression with a Contact Face of 25 x 40mm with connection of your choice.	8 x 15mm	38°, 45°, 60°, 70°	2MHz, 4MHz
	XLTAC	Extra Large Twin Angle Compression with a Contact Face of 50 x 32mm with connection of your choice.	10 x 20mm	38°, 45°, 60°, 70°	2MHz, 4MHz

Single 0° Compression Transducers

Single 0° Compression Normal beam direct contact Transducers

- Designed for the inspection of Plates, Billets, Bars, Forgings, Castings, Extrusions and many other metallic and non metallic components
- Available with a soft face, ceramic face or our bespoke steel face for extended wear in a variety of testing conditions
- Ergonomically designed housings for comfort grip



Images	Order Code	Description	Crystal Size	Contact Face	Standard Frequency
	SMSC	Sub Miniature Single Compression with connection of your choice	Ø6.3mm	Ø10.2mm	5MHz, 10MHz
	SCDL	Single Compression Delay Line with connection of your choice	Ø1/4in	Ø7.6mm	5MHz, 10MHz
	SCLP	Single Compression Low Profile with connection of your choice	Ø10mm	Ø14mm	2.5MHz, 5MHz
		Single Compression Low Profile with connection of your choice	Ø20mm	Ø32.5mm	2MHz, 2.5MHz, 4MHz, 5MHz
	SCSF	Single Compression Soft Faced with connection of your choice with 4 additional membranes, also available to buy in packs see accessories	Ø10mm	Ø16mm	2MHz, 2.5MHz, 4MHz, 5MHz
			Ø24mm	Ø33mm	2MHz, 4MHz







Single 0° Compression Transducers

Single 0° Compression Normal beam direct contact Transducers

- Designed for the inspection of Plates, Billets, Bars, Forgings, Castings, Extrusions and many other metallic and non metallic components
- Available with a soft face, ceramic face or our bespoke steel face for extended wear in a variety of testing conditions
- Ergonomically designed housings for comfort grip







Images	Order Code	Description	Crystal Size	Contact Face	Standard Frequency
	SCHF	Single Compression Hard Faced (Ceramic Type) with connection of your choice	ø10mm	ø20mm	2MHz, 2.5MHz, 4MHz, 5MHz
			ø15mm	ø32mm	2.5MHz, 4MHz, 5MHz
			ø20mm	ø32mm	2MHz, 2.5MHz, 4MHz, 5MHz
	SC	Single Compression Steel Faced with connection of your choice	ø10mm	ø15mm	2MHz, 2.5MHz, 4MHz, 5MHz
			ø15mm	ø21mm	2.5MHz, 4MHz, 5MHz

Twin 0° Compression Transducers

Twin 0° Compression Normal beam direct contact Transducers

- Normal beam compression (longitudinal) waves
- Available in a range of sizes from button probe to large 24mm diameter
- Available in a range of housing material from plastic, aluminium to robust stainless steel
- Wear faces are thicker than industry standard allowing extended life
- Contoured contact face available to match convex and concaved testing surfaces







Images	Order Code	Description	Crystal Size	Contact Face	Standard Frequency
	DTC	Twin Compression with connection of your choice	Ø10mm	Ø14mm	5MHz
	TCLP	Twin Compression Low Profile with connection of your choice	Ø5mm	Ø8.5mm	5MHz, 10MHz
	SMTC	Sub Miniature Twin Compression with 2 Meter Integral cable with connection of your choice.	Ø6.3mm	Ø10mm	5MHz, 10MHz
	MTC	Miniature Twin Compression with 2 Meter Integral Cable with connection of your choice.	Ø10mm	Ø14mm	5MHz

Twin 0° Compression Transducers

Twin 0° Compression Normal beam direct contact Transducers

- Normal beam compression (longitudinal) waves
- Available in a range of sizes from button probe to large 24mm diameter
- Available in a range of housing material from plastic, aluminium to robust stainless steel
- Wear faces are thicker than industry standard allowing extended life
- Contoured contact face available to match convex and concaved testing surfaces



Images	Order Code	Description	Crystal Size	Contact Face	Standard Frequency
	TC	Twin Compression Stainless Steel housing with connection of your choice	Ø10mm	Ø18mm	2MHz, 2.5MHz, 4MHz, 5MHz
			Ø15mm	Ø21mm	2.5MHz, 4MHz, 5MHz
			Ø20mm	Ø26mm	2MHz, 2.5MHz, 4MHz, 5MHz
	TCP	Twin Compression Plastic (Black Acetal) housing with connection of your choice	Ø10mm	Ø18mm	2MHz, 2.5MHz, 4MHz, 5MHz
	TCA	Twin Compression Aluminium housing with connection of your choice	Ø10mm	Ø18mm	2MHz, 2.5MHz, 4MHz, 5MHz

Twin 0° Compression Transducers

Twin 0° Compression Normal beam direct contact Transducers

- Normal beam compression (longitudinal) waves
- Available in a range of sizes from button probe to large 24mm diameter
- Available in a range of housing material from plastic, aluminium to robust stainless steel
- Wear faces are thicker than industry standard allowing extended life
- Contoured contact face available to match convex and concaved testing surfaces



Images	Order Code	Description	Crystal Size	Contact Face	Standard Frequency
	TCSF	Twin Compression Soft Faced with connection of your choice with 4 additional membranes also available to buy in packs see accessories	ø10mm	ø18mm	2MHz, 4MHz, 5MHz
			ø24mm	ø33mm	2MHz, 4MHz
	TCE	Twin Compression Aluminium (Square faced housing) with connection of your choice (TCE10 also available in a Plastic (Black Acetal) housing) TCEP	ø10mm	ø18mm	2MHz, 2.5MHz, 4MHz, 5MHz
			ø15mm	ø21mm	2.5MHz, 4MHz, 5MHz
			ø20mm	ø26mm	2MHz, 2.5MHz, 4MHz, 5MHz
	PT	Plate Tester Transducer with connection of your choice	ø20mm	ø25mm	2.5MHz, 4MHz

High Temperature Transducers

Provides excellent sensitivity at high temperatures for intermittent use:

- “H” Range capable of intermittent testing up to 200°C
- “GH” Range capable of intermittent testing up to 300°C



The vast majority of our Transducers can be manufactured as a high temperature version to suit intermittent testing ranges of either 200°C or 300°C.

Please contact our Sales team for further information and prices of our high temperature range of products.

“H Range”



“GH Range”

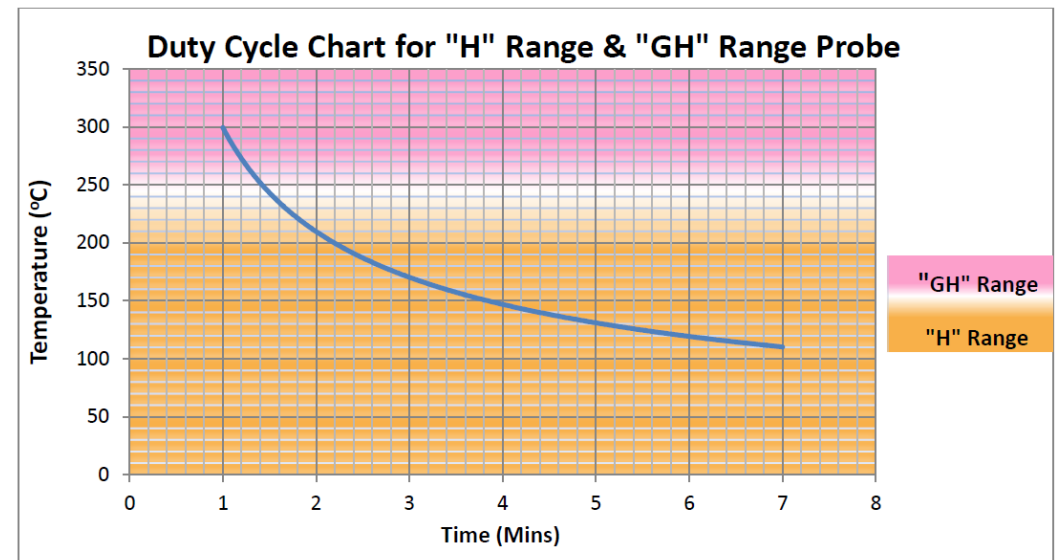



Creep Wave & Surface Wave Transducers







Creep Wave direct contact Transducers

- Creates a sound wave that travels along the material just beneath the surface (1-3mm)

Images	Order Code	Description	Crystal Size	Standard Frequency
	CW	Creep Wave Transducer with a Contact Face of 27 x 16mm	5 x 10mm	2MHz, 4MHz, 5MHz
	LCW	Large Creep Wave Transducer with a Contact Face of 40 x 25mm	8 x 15mm	2MHz, 4MHz, 5MHz
	XLCW	Extra Large Creep Wave Transducer with a Contact Face of 50 x 32mm	10 x 20mm	2MHz, 4MHz, 5MHz

Surface Wave direct contact Transducers

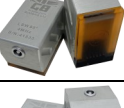
- Creates a sound wave that travels along the surface of the material being inspected
- Available with a robust metal housing

Images	Order Code	Description	Crystal Size	Standard Angles	Standard Frequency
	SW90	Surface Wave Single Shear 90° High Performance with a Contact Face of 29 x 16mm	ø10mm	90°	2MHz, 4MHz
	MSW90	Surface Wave Single Shear 90° with a Contact Face of 27 x 16mm	8 x 9mm	90°	2MHz, 4MHz
	LSW90	Surface Wave Large Single Shear 90° with a Contact Face of 40 x 25mm	ø15mm	90°	2.5MHz, 4MHz
	XLSW90	Surface Wave Extra Large Single Shear 90° with a Contact Face of 50 x 32mm	20 x 20mm	90°	2MHz, 4MHz

integral-TOFD

Integral-TOFD, designed and manufactured by GB Inspection Systems Ltd, is yet another innovative Patented product which has been made as an alternative to the traditional TOFD wedge and transducer offering.

See below the main benefits:

- *Faster and easier setup time* —No connection between transducer and wedge necessary
- *Consistent sensitivity* —No couplant inconsistencies between transducer and wedge pairing
- *Greater reliability* —Transducer and wedge cannot become loosened / unscrewed during scanning.
- Eliminates the risk of separation between transducer and wedge
- Available in a variety of footprint sizes, angles, frequencies and crystal sizes upon request
- Available with *integral-PALM™*

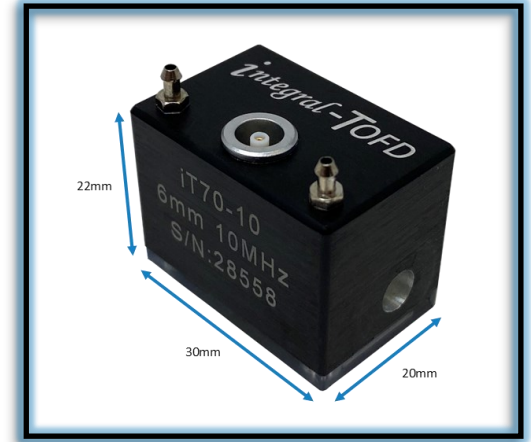

Order Code	Description	Crystal Size	Standard Angles	Standard Frequency
iT	Integral TOFD Composite Crystal Compression Wave with Contact Face of 30 x 20mm	3mm, 6mm	45°, 60°, 70°	5MHz, 10MHz
iTL	Large Integral TOFD Composite Crystal Compression Wave with Contact Face of 30 x 30mm	12mm	45°, 60°, 70°	5MHz, 10MHz



LIMBOTOFD™



Our Low Profile Integral TOFD Transducer allows you to inspect where other Transducers can't...

Unique Features and Benefits of the Patented LIMBOTOFD™

- *Low Profile* - Only 10mm high allowing easy access to previously inaccessible areas which are currently untestable using conventional TOFD transducers
- *Reduces inspection cost* - No need to implement other possibly disruptive inspection methods such as Radiography
- *High signal to noise* - Single cycle responsiveness using a frequency of 10 or 15 MHz
- *Integral Wedge* - Unique patented design providing convenient use without the need to change wedges providing the assurance of the transducer/wedge couplant film.
- *Increases productivity* - With conventional TOFD, losing a transducer may result in the loss of the use of its dependent wedges and forcing the inspection to stop, **LIMBOTOFD™** eliminates this risk.
- Available with **integral-PALM™**



Order Code	Description	Crystal Size	Position	Standard Angles	Standard Frequency
LTOFD	LIMBOTOFD™ Composite Compression Wave with integral cable with Contact Face of 22(B) x 10.5(C)mm	ø3mm, ø6mm	L (Front), R (Rear)	45°, 60°, 70°	10MHz, 15MHz

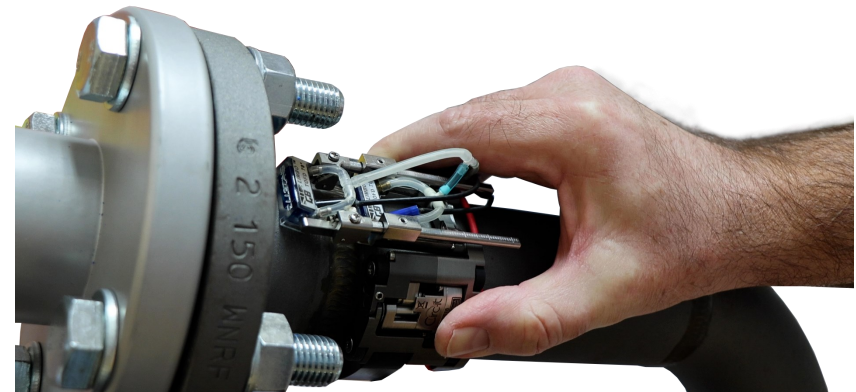
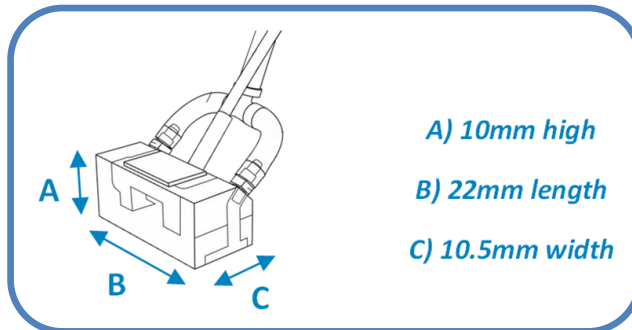

integral-PALM™

“Ultrasonic Scanning in the palm of your hand.”



Why Choose *integral-PALM*™ ?????

The *integral-PALM*™ isn't just another scanner, it's a game-changer.

It combines the power of advanced technology with the convenience of portability, ensuring that ultrasonic testing is more efficient, accurate, and reliable than ever before, with the choice of either **TOFD** transducers or multiple conventional transducers set across the scanner footprint creating a multi-test pulse echo **ARRAY**.

Rapid Scanning and data collection -The *integral-PALM*™ delivers fast set-up, accurate, repeatable results, reducing downtime and increasing productivity, simply provide diameters of the pipes being tested and will model to suit.

TOFD-Available with either a made to measure PCS and Weld Cap allowance or an adjustable PCS both with built in *integral*-TOFD transducers.

ARRAY-Available with as many Pulse-Echo transducers as we can fit into the platform, Shear, Compression, Angle Compression, Surface Wave, many available with differing foot-prints and Crystal specification available.

integral-PALM™ Available to cover the majority of our range.

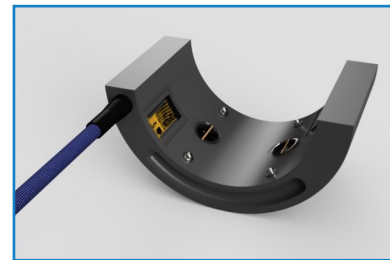
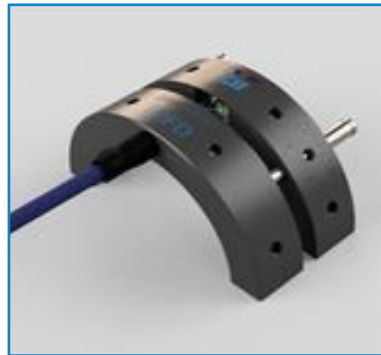
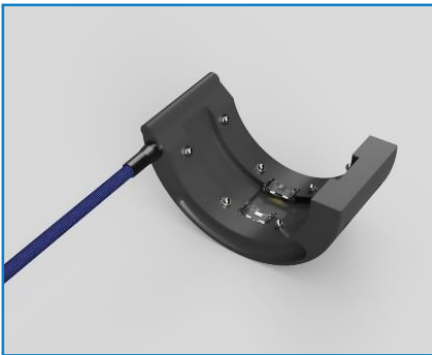

TULA™



Used for Early Detection of HTHA (High Temperature Hydrogen Attack)

These Transducers are proving to offer high resolution detection capabilities in a fast, convenient and economical package allowing easy deployment and compatibility with existing and popular ultrasonic instruments.

Our Patented TULA accommodates Ultrasonic inspection for the detection of HTHA / flaws in welds, or plate inside surfaces, mid section and upper surfaces, and also allows a one sided inspection where the access is difficult to place a Transducer.

See below the main benefits:

- TOFD principle, in one housing
- Suite of TULA probes with defined focussing/inspections
- TULA probes are designed to specifically identify early stages of HTHA (High Temperature Hydrogen Attack) in varying materials
- Further variants can be manufactured to suit specific customer requirements
- Ease of deployment, probes can be used by hand or with simple encoded scanners









Our TULA Transducers come in a plastic case including foam specifically designed for this suite of Transducers. This makes for easy, comfortable transportation to and from site.

Order Code	Description	Crystal Size	Standard Frequency
TULA-A	TULA™ TOFD Ultra Low Angle (0° roof angle)	ø6mm	10MHz
TULA-B	TULA™ TOFD Ultra Low Angle (Focus 10mm)	ø6mm	10MHz
TULA-C	TULA™ TOFD Ultra Low Angle (Focus 25mm)	ø6mm	10MHz
TULA-C+ 12.5	TULA™ TOFD Ultra Low Angle (Focus 25mm) 12.5°	ø6mm	10MHz
TULA-C+ 25	TULA™ TOFD Ultra Low Angle (Focus 25mm) 25°	ø6mm	10MHz
TULA-D	TULA™ TOFD Ultra Low Angle 60° (No Focus)	ø6mm	10MHz
TULA-E	TULA™ TOFD Ultra Low Angle 60° (25mm Focus)	ø6mm	10MHz
TULA-F	TULA™ TOFD Ultra Low Angle 60° (No Focus)	ø6mm	5MHz



- Leading range of axle inspection Transducers approved by many specifiers and OEM's
- BNC connectors as standard can be positioned top, rear or side of the Transducer housing subject to customer specific requirements (EPOA)





Images	Order Code	Description	Crystal Size	Standard Angles	Standard Frequency
	LSSBR	Large Single Shear Axle Transducer with a Contact Face of 25 x 40mm with connection of your choice & Calibration Certificate and label	ø15mm	37°, 45°, 60°, 70°, 90°	2.5MHz
	XLSSBR	Extra Large Single Shear Axle Transducer with a Contact Face of 50 x 32mm with connection of your choice & a Calibration Certificate and label	20 x 20mm	38°, 45°, 60°, 70°, 90°	2.5MHz
	MHAT(S/L)	Manual Hollow Axle Test Transducer Forward/Rearward for MHAT head Type with a Contact Face per Transducer of 16 x 29mm, connection of your choice & Calibration Certificate	ø10mm	38°, 45°, 60°, 70°	5MHz
Images	Order Code	Description	Crystal Size	Face Angle	Standard Frequency
	TCBR	Twin Compression Axle Transducer 0° with a Contact Face of 28 x 32mm with connection of your choice & Calibration Certificate and label	20 x 10mm	Any angle up to 25°	2.5MHz
	LTCBR	Large Twin Compression Axle Transducer 0° with a Contact Face of 32 x 38mm with connection of your choice & Calibration Certificate and label	20 x 10mm	Any angle up to 25°	2.5MHz
Images	Order Code	Description	Crystal Size	Contact Face	Standard Frequency
	SCBR(S)	Single Compression Axle Transducer Small Type with connection of your choice & Calibration Certificate and label	ø20mm	ø21mm	2.5MHz, 4MHz
	SCBR(L)	Single Compression Axle Transducer Large Type with connection of your choice & Calibration Certificate and label	ø20mm	ø31mm	2.5MHz, 4MHz
	SCLPi	Single Compression Low Profile with integral cable with Calibration Certificate and label	ø10mm	ø14mm	2.5MHz



Railway — Track Transducers

- Network Rail Approved among many other owner and operators
- High signal to noise ratio
- Provides an unambiguous response



Images	Order Code	Description	Crystal Size	Standard Angles	Standard Frequency
	LSST	Large Single Shear Track with connection of your choice & Calibration Certificate and label	ø15mm	38°, 40°, 45°, 70°	2.5MHz, 4MHz
Images	Order Code	Description	Crystal Size	Contact Face	Standard Frequency
	SCT	Single Compression Track 0° with connection of your choice & Calibration Certificate and label	ø15mm	ø19mm	2.5MHz
	TCT	Twin Compression Track 0° with connection of your choice & Calibration Certificate and label	ø10mm	ø18mm	5MHz





Railway — Track Transducers

- Network Rail Approved among many other owner and operators
- High signal to noise ratio
- Provides an unambiguous response



Rail Track Accessories	
Order Code	Description
RWTJa-1	Rail Weld Track Jig (Aluminium) - Tandem probe holder (LSST(NR) Range) with 200mm rule
RWTJs-1	Rail Weld Track Jig (Stainless Steel) - Tandem probe holder (LSST(NR) Range) with 200mm rule



RWTJ-1a

Rail Axle Accessories	
Order Code	Description
MHAT-KIT	Manual Hollow Axle Ultrasonic Test System, up to $\varnothing 110\text{mm}$ Head including probes, graduated handle, pressure couplant and case

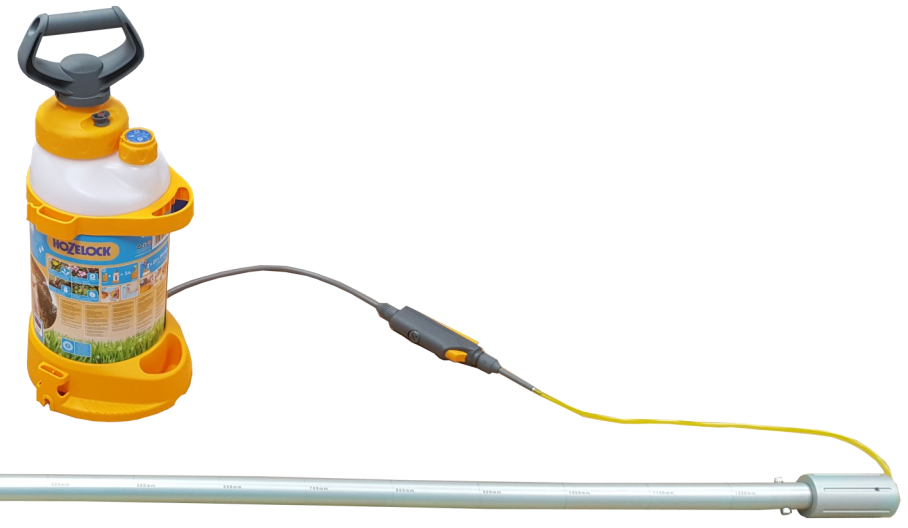



Railway — Track, Network Rail approved Transducers







GB Inspection Systems is pleased to announce that we have been awarded Certificate of Acceptance for manufacturing Network Rail Ultrasonic Transducers (PA05/06763).



Certificate of Acceptance

PA05/06763

Network Rail Approved

Images	Order Code	Description	Crystal Size	Standard Angles	Standard Frequency
	LSSNR	Large Single Shear Track with Rear Entry Subvis Connection with Calibration Certificate and label, NR Catalogue# 0094/016065	ø15mm	38°, 40°, 45°, 70°	2.5MHz
	LSSTNR	Large Single Shear Track with Top Entry BNC Connection with Calibration Certificate and label	ø15mm	45°, 70°	2.5MHz
	SSNR	Single Shear 70° 4MHz (ø10mm) with Top Entry Subvis Connection with Calibration Certificate and label, NR Catalogue # 0094/016068	ø10mm	70°	4MHz
Images	Order Code	Description	Crystal Size	Contact Face	Standard Frequency
	TCNR	Twin Compression Track 0° option for Focus 10.185mm with Subvis Connection with Calibration Certificate and label	ø10mm	ø19mm	5MHz
	SCNR	Single Compression Track with Subvis Connection with Calibration Certificate and label, NR Catalogue# 0094/016063	ø15mm	ø18mm	2.5MHz



Transducer Cables

- All Cables are manufactured with RG174 as standard unless otherwise stated
- Other Connectors, Cable Types and Lengths available upon request (£POA)
- Genuine Lemo Parts used

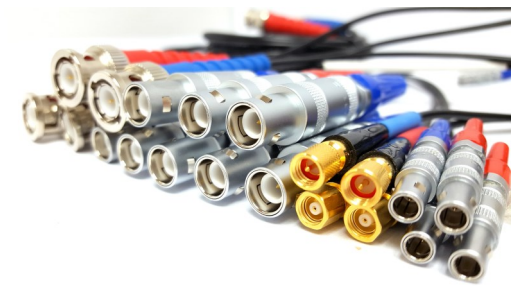

Single Cable	
Order Code	Description
PC-BNC-BNC	Transducer Cable / BNC to BNC connector
PC-BNC-BNC PRS	Transducer Cable / BNC to BNC (Pairs)
PC-BNC-BNC1	Transducer Cable / BNC to BNC connector, 1M
PC-BNC-BNC1M PRS	Transducer Cable 1M/BNC-BNC RG58(Pairs) 1 x Red 1 x Blue
PC-BNC-S	Transducer Cable / BNC to Subvis connector
PC-BNC-ML	Transducer Cable / BNC to Lemo 00 connector
PC-BNC-MMD	Transducer Cable / BNC to Mini Microdot connector RG178
PC-BNC-MD	Transducer Cable / BNC to Microdot connector
PC-BNC-WUHF	Transducer Cable / BNC to WUHF connector
PC-L-L	Transducer Cable / Lemo 01 to Lemo 01 connector
PC-L-S	Transducer Cable / Lemo 01 to Subvis connector
PC-L-ML	Transducer Cable / Lemo 01 to Lemo 00 connector
PC-L-MD	Transducer Cable / Lemo 01 to Microdot connector
PC-L-BNC	Transducer Cable / Lemo 01 to BNC connector(RG58)
PC-L-BNC(RG174)	Transducer Cable / Lemo 01 to BNC connector (RG174)
PC-L-WUHF	Transducer Cable / Lemo 01 to WUHF connector
PC-ML-ML	Transducer Cable / Lemo 00 to Lemo 00 connector
PC-ML-S	Transducer Cable / Lemo 00 to Subvis connector
PC-ML-MD	Transducer Cable / Lemo 00 to Microdot connector
PC-L1B304-L1B304	Encoder Cable Special PC/L1B304-L1B304 8ft long

Twin Cable	
Order Code	Description
PCT-BNC-BNC	Twin Transducer Cable / BNC to BNC connector(RG174)
PCT-BNC-S	Twin Transducer Cable / BNC to Subvis connector
PCT-BNC-ML	Twin Transducer Cable / BNC to Lemo 00 connector
PCT-BNC-MD	Twin Transducer Cable / BNC to Microdot connector
PCT-L-L	Twin Transducer Cable / Lemo 01 to Lemo 01 connector
PCT-L-S	Twin Transducer Cable / Lemo 01 to Subvis connector
PCT-L-ML	Twin Transducer Cable / Lemo 01 to Lemo 00 connector
PCT-L-MD	Twin Transducer Cable / Lemo 01 to Microdot connector
PCT-L-BNC	Twin Transducer Cable / Lemo 01 to BNC connector
PCT-L-DM	Twin Transducer Cable / Lemo 01 to DM connector
PCT-ML-ML	Twin Transducer Cable / Lemo 00 to Lemo 00 connector
PCT-ML-S	Twin Transducer Cable / Lemo 00 to Subvis connector
PCT-ML-MD	Twin Transducer Cable / Lemo 00 to Microdot connector
PCT-ML-DM	Twin Transducer Cable / Lemo 00 to DM connector
PCT-DM-DM	Twin Transducer Cable / DM to DM connector
PCT-DM-MD	Twin Transducer Cable / DM to Microdot connector
PCT-DM-S	Twin Transducer Cable / DM to Subvis connector



Transducer and Cable Accessories

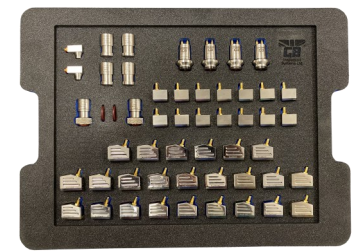

Transducer Accessories	
Order Code	Description
MHAT-SKIDS	Hollow Axle Test Head - Replacement set of Skids, Springs and Screws
RWTJ -A	Accessories for RWTJ-1
JIR-DJG012	JIREH Circ-it Adaptor for LIMBOTOFD™
PH-LimAD	PHOENIX ISL Adaptor for LIMBOTOFD™ - UNDER REDEVELOPMENT
COB-LimAD	OLYMPUS COBRA Adaptor for LIMBOTOFD™ - UNDER DEVELOPMENT
DL5	Delay Line for SCDL6-5 & SCDL6-10
GS24	Replaceable Membrane Ø24mm - Pack of 10 for 10mm Transducers.
GS45	Replaceable Membrane Ø45mm - Pack of 10 For 24mm Transducers.
SSWS	Wear Shoes (pack of 10) for SS & MWS Transducers-Dimension: 25.7 x 15.6 x 3 mm
SSWSK	Wear Shoes includes Cork (pack of 10) for TS & MWT Transducers Dimension: 25.7 x 15.6 x 3 mm
SSWSTS	Wear Shoe (pack of 10) for SS & MWS Thick Shoe Transducers - Dimensions 25 x 15.5 x 4mm
TC10RSK	TC10 Re-Shoe Kit includes Cork (Pack of 10) 18mm Ø
TC15RSK	TC15 Re-Shoe Kit includes Cork (Pack of 10) 21mm Ø
TC20RSK	TC20 Re-Shoe Kit includes Cork (Pack of 10) 26mmØ
LWS	Wear Shoes (pack of 10) for LSS Transducers - Dimensions 35 x 25.5 x 4mm
LWS-Short Series	Wear Shoes (pack of 10) for LSS Short Series Transducers - Dimensions 33.5 x 25 x 3mm
XLSS-RS	XLSS Re-Shoe Kit (Pack of 10)
TCEWR-SS	Wear Ring for TC10 Transducers (Stainless Steel) Diameter 10mm
TCEWR-B	Wear Ring for TC10 Transducers (Brass) Diameter 10mm
TCE15WR-SS	Wear Ring for TC15 Transducers (Stainless Steel) Diameter 15mm
TCE15WR-B	Wear Ring for TC15 Transducers (Brass) Diameter 15mm
TCE20WR-SS	Wear Ring for TC20 Transducers (Stainless Steel) Diameter 20mm
TCE20WR-B	Wear Ring for TC20 Transducers (Brass) Diameter 20mm
WR10	Wear Ring for 10mm Soft Face Transducers
WR24	Wear Ring for 24mm Soft Face Transducers

Cable Accessories	
Order Code	Description
BNC-L	Adaptor BNC / Lemo 01
L-BNC	Adaptor Lemo 01 / BNC
L-MLF	Adaptor, Lemo 01 to Lemo 00 Female
ML-BNC	Adaptor Lemo 00 / BNC
ML-LF	Adaptor, Lemo 00 to Lemo 01 Female
?-? PL	Patch Lead to suit different connectors, available Single or Twin



Cases and Bespoke Foam

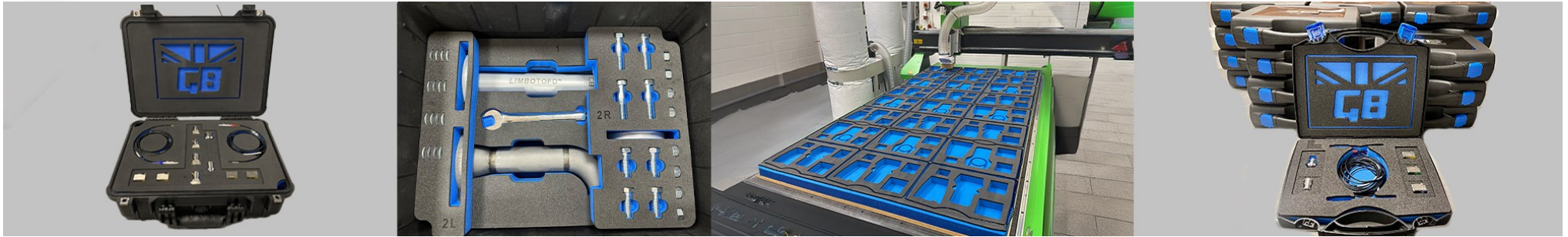

Equipment Cases	
Order Code	Description
PCASE125	Plastic Case, Black with Blue clips - Size 197 x 167 x 47mm (Int 180 x 125 x 42mm) Including bespoke foam inserts to suit contents
PCASE155	Plastic Case, Black with Blue clips - Size 244 x 207 x 59mm (Int 225 x 155 x 53mm)- Including bespoke foam inserts to suit contents
PCASE175	Plastic Case, Black with Blue clips - Size 275 x 231 x 65mm (Int 255 x 175 x 60mm) Including bespoke foam inserts to suit contents
PCASE195	Plastic Case, Black with Blue clips - Sixe 307 x 260 x 74mm (Int 284 x 195 x 66mm) Including bespoke foam inserts to suit contents
PCASE220	Plastic Case, Black with Blue clips - size 346 x 292 x 84mm (Int 320 x 220 x 78mm) Including bespoke foam inserts to suit contents
PCASE250	Plastic Case, Black with Blue clips - size 393 x 331 x 95mm (Int 365 x 250 x 85mm) Including bespoke foam inserts to suit contents
PCASE290	Plastic Case, Black with Blue clips - size 456 x 384 x 110mm (Int 421 x 290 x 100mm) Including bespoke foam inserts to suit contents
PCASE57455	Plastic Case, Transparent 86 x 40mm Including foam insert
PCASE57436	Plastic Case, Transparent 67 x 40mm including foam insert
PELI IM2200	Peli Case IM2200 (Intl Dim 381 x 267 x 157mm, Lid Depth 51mm, Base Depth 101mm) with CNC Profiled Foam
	Bespoke custom Foam Inserts



Other Cases, Peli Cases with custom foam available upon request. Please contact our sales team on sales@gbinspection.com for all of your case needs.



Calibration Blocks

We offer and manufacture a full range of Calibration Blocks, standard and custom made including Phased Array.

Most of the Calibration Blocks can be manufactured out of a material you specify for example Carbon Steel, Stainless Steel or Aluminium or even your own supply.

Full traceability is guaranteed and Individual Certification is provided for every Calibration block.

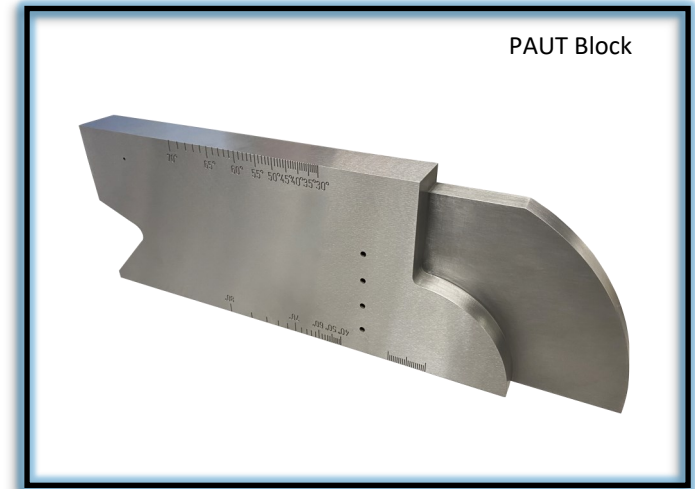

PAUT Block

Some of our standard blocks include:

Order Code	Description
APTB-1	APTB-1 Calibration Block with Conformity Certificate
IOW-A5	IOW (A5) Calibration Block with Conformity Certificate
V1(A2)	V1 Calibration Block (25x100x300mm with 1.5mm hole) with Conformity Certificate
V2-12.5	V2 12.5 x 1.5mm hole Calibration Block with Conformity Certificate
V2-20	V2 20 x 1.5mm hole Calibration Block with Conformity Certificate
1-8SW	1-8mm Step Wedge (+ Thickness step 15 & 20mm) Calibration Block with Conformity Certificate
CB88M	CB88 Metric Calibration Block with Conformity Certificate
No.1	No.1 Calibration Block (25 x 100 x 300mm) Target Hole 3mm without Plastic Insert with Conformity Certificate

For more options of Calibration Blocks contact our sales team where they will be happy to help:

sales@gbinspection.com or +44 (0)121 351 5025





Custom Made Transducers

GB Inspection Systems have manufactured bespoke Transducers for over 30 years, covering a wide range of applications.

From simple contouring of Transducers used on pipe testing or providing special housings for easier access on test areas to Transducers designed for your specific testing applications.

Some typical applications for which we have manufactured Transducers are:

- Bore probe for turbine rotor inspection
- Railway probes for track and axle testing
- Turbine blade probes for steam turbine blades
- Time of flight probes for Inconel inspection
- Transducers for automatic test systems
- Through-transmission probes and single probes to detect the presence of fluids
- Probes for nuclear plant inspection
- High temperature probes for petro-chemical plant and oil pipeline inspection
- Underwater test probes for oil platforms
- Aerospace application

**Extra Miniature Single Shear 55°
with ϕ 6.3mm Crystal in tandem
5MHz with Lemo 00 Connectors**



**Sub-miniature
Bi-directional Shear 45°
5MHz with integral Cable
BNC**



**Stick Probe
Low Profile Twin Compression ϕ
10mm Composite Crystal 2MHz
with 9in Stick Handle & 4Ft Cable**



Certification of Transducers

We offer 4 "standard" certificates as listed below with examples

- ICO-CON—Individual Certificate of Conformity in accordance with BS EN ISO 22232-2:2020
- ICO-CAL—Individual Certificate of Calibration with detailed test results in accordance with BS EN ISO 22232-2:2020
- ICO-CALW—Individual Certificate of Calibration including waveform and test results in accordance with BS EN ISO 22232-2:2020
- ICO-CALTEST—Individual Certificate of Calibration with detailed test results compliant to BS EN ISO 22232-2:2020

We also offer a range of Export Documentation for International shipments. The order will be supplied with a commercial invoice and packing list Free of Charge, any Country or Customer specific documentation will be charged extra (costs TBC at order stage). Examples include: Certificate of Origin, ATR 1, EUR 1

www.gbinspection.com
Tel: +44 (0)121 351 5025

Certificate of Conformity

Certificate Number: 53972
Issue Date: 01/09/2021
Probe Test Number: 53972
Probe Model: TC10-5(ML)
Probe Description: Twin Compression 5MHz (ø10mm) with Lemo 00
Probe Serial Number: 40327
Specification / Drawing Number: BS EN ISO 22232-2:2020

CONDITION OF MATERIALS
In accordance with BS EN ISO 22232-2:2020
"Non-destructive testing. Characterization and verification of ultrasonic examination equipment. Probes."

DEVIATIONS
None

It is Certified that the whole of the supplies detailed hereon have been manufactured, inspected and tested and unless otherwise stated above, conform in all aspects to the requirements of the contract or purchase order and are in accordance with our Quality Management System.

APPROVED SIGNATORY / STAMP
FOR & ON BEHALF OF GB INSPECTION SYSTEMS LTD

GB Inspection Systems Ltd
ICO-CALTEST
Model: TC10-4(C3.5X10)(ML)
S/N: 12345

TC10-4(C3.5X10)(ML)	
Probe Weight	42g
Type of Connector	Lemo 00
Crystal Material	Lead Dioxide Titanate
Crystal Size	3.5 x 10 mm
Crystal Frequency	4MHz
Wedge Material	Lucite
Maximum Allowable Wear	3 mm
Roof angle of Crystals	5°
Case Material	Stainless Steel
Type of Focus	Focused
Focal Distance	7.5 mm
Wedge Path Delay	24.4 mm
Divergence Vertical Plane	5.5°
Divergence Horizontal Plane	5.5°
Width of the focal zone	7.3 mm
Length of the focal zone	22.5 mm
Operating Temperature	20° ± 5°
Storage Temperature	20° ± 5°
Test Conditions	9% to 90% (intermittent use at high temperatures)

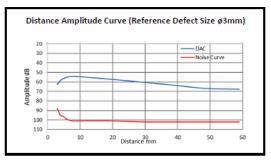
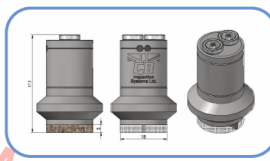

Flaw Detector Settings

Filter	100 V
Damping	50 D
Pulse Repetition Frequency	150 Hz
Pulse Width	5µs
Velocity	5930 m/sec
Frequency	3.8 MHz

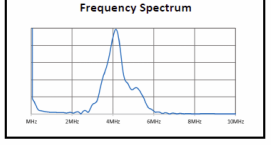

Test Results

Centre Frequency	4.09 MHz
-6dB Upper Frequency	4.53 MHz
-6dB Lower Frequency	3.65 MHz
Bandwidth	0.88 MHz
Pulse Echo Sensitivity	-47.39 dB
Pulse Duration	0.89 µs
Crystals	40 dB
Instruments	Sonatest 700K, Oscilloscope MD04048-3

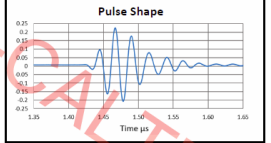

Typical performance of the aforementioned probe type. GB Inspection Systems Limited probes are manufactured to the highest standard for quality, reliability and performance within our registered quality system. Each probe is individually serialised and tested to the latest industry standard. BS EN ISO 22232-2

GB Inspection Systems Ltd
22a Cobbett Road
Burntwood Business Park
Burntwood, Cannock
Staffordshire, WS7 3GL UK

T +44 (0) 121 351 5025
F +44 (0) 154 327 9619
E enquiries@gbinspection.com
W www.gbinspection.com
Company Registration Number: 3021487



www.gbinspection.com
Tel: +44 (0)121 351 5025

Certificate of Calibration

Certificate Number: 57914
Issue Date: 19/10/2021
Probe Test Number: 57914
Probe Manufacturer: GB Inspection Systems Ltd
Probe Model: GHSMTCS-5(L)
Probe Serial Number: 42505
Specification: BS EN ISO 22232-2:2020
Probe Description: GH Range + High Temperature Sub Miniature Twin Crystal 5MHz (Ø6.3mm) with Lemo 01
Deviations: None

Test Results	
25 BWE	50.5 dB Pass
Frequency	5.1 MHz Pass
Pulse Length	0.9 µs Pass
Spurious Long Range Echo	14 dB Pass
ø1.5mm Hole At Range 10mm	55.5 dB Pass
Short Range Internal Echoes	32 dB Pass
Beam Angle	0° Pass

Test Equipment Used
Test No 57914, Test Cell 2
Instrument Type, Description & Serial Number
Test Block - CW Calibration Block - 6000152
Test Block - V2 25mm Calibration Block - 600083
Test Block - 50mm Radius Block with 1.5mm - 600136
Test Block - V1 Calibration Block 607-767 - 600071
Test Block - V2 12.5mm 1.5mm Hole Calibration Block Aluminium - 8
Flaw Detector - Sonatest MasterScan 700 - 024446
Test Block - APT8-1 DRG 2.5, 10mm - 1907
Test Block - CB7M - 18/20/05
Test Block - APT8-1 DRG 2.5, 10mm - 1907
Test Block - CB7M - 18/20/05
Test Block - CB88 Calibration Block - 94/02
Test Block - TULA Stepped Test Block 10-3mm - 600331
Test Block - TULA Stepped Test Block 22-24mm - 600332
Oscilloscope - Tektronix MDO4048-3 - 0102114
Test Block - V2 12.5mm Calibration Block - 6002390
Test Block - APT8-2 DRG 2.5, 10mm - 24256

Limit of uncertainty: ± 0.5°, ± 0.05MHz, ±1dB

Test Block - V1 Calibration Block - GBT2288
Test Block - 50mm Radius Block ESI STD 90-8 - 600137
Test Block - LOW Beam Profile Block - 600092
Test Block - V1 Calibration Block 38°66° - 600074
Flaw Detector - Krautkramer USN5BL AD30758 1/2 - 0209HF
Oscilloscope - Tektronix MDO4048-3 - 0202619
Test Block - V2 25mm Calibration Block - 600461
Test Block - V2 25mm Calibration Block - 14/47/01
Test Block - 1.5mm Step Wedge - GBT2291
Test Block - TULA Stepped Test Block 6-8mm - 600300
Test Block - TULA Stepped Test Block 25-28mm - 600313
Flaw Detector - Sonatest MasterScan 700 - 024395
Flaw Detector - Sonatest MasterScan 700 - 020401

The list above shows all equipment which is located in the Test Cell 2, however please note not all equipment was used during this test.

In accordance with BS EN ISO 22232-2:2020
"Non-destructive testing. Characterization and verification of ultrasonic examination equipment. Probes."

GB Inspection Systems Ltd
22a Cobbett Road
Burntwood Business Park
Burntwood, Cannock
Staffordshire, WS7 3GL UK

T +44 (0) 121 351 5025
F +44 (0) 154 327 9619
E enquiries@gbinspection.com
W www.gbinspection.com
Company Registration Number: 3021487

GB Inspection Systems Ltd
22a Cobbett Road
Burntwood Business Park
Burntwood, Cannock
Staffordshire, WS7 3GL UK

T +44 (0) 121 351 5025
F +44 (0) 154 327 9619
E enquiries@gbinspection.com
W www.gbinspection.com
Company Registration Number: 3021487



Calibration, Service and Repair

GB Inspection has many years' experience in the repair, service and calibration of all makes of Ultrasonic, Eddy Current and Magnetic Particle Inspection equipment.

All the leading makes of equipment are catered for and we offer a fast, reliable and competitive service.

All calibration readings and results are traceable to national standards. Prices are available upon request.

Examples-

- Ultrasonic Transducers
- Calibration Blocks
- Ultrasonic Flaw Detectors
- Ultrasonic Thickness Meters
- Eddy Current Equipment
- Rail Test Trolleys
- Magnetic Yokes
- Electro Magnets
- Magnetometers
- Field Strength Meters
- Bench Units
- Phased Array PAUT
- Portable Transformers
- UV Lamps & Meters
- Clamp Meters
- Densitometers
- Radiation meters

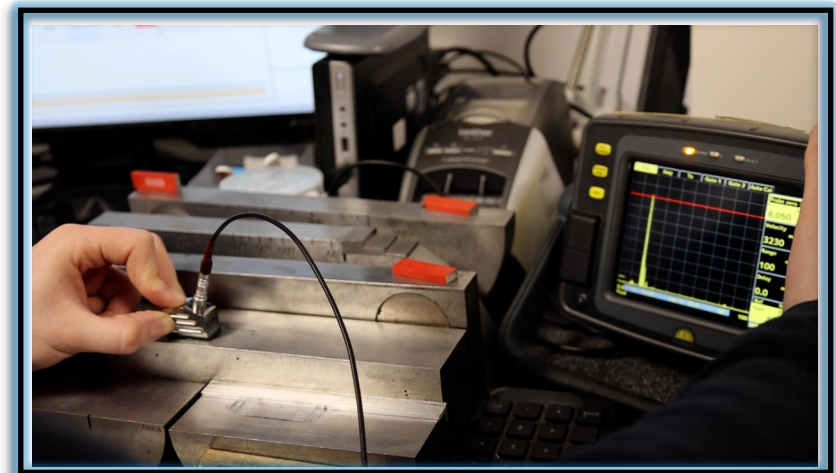
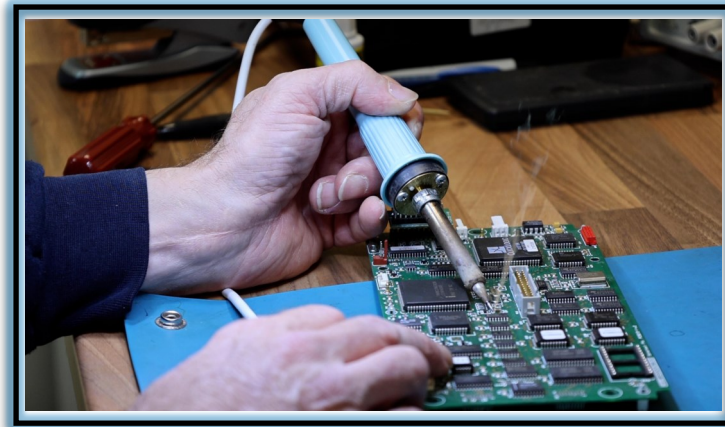



NDT Equipment and Consumables

As we are an independent company not tied to any one manufacturer, we can offer you a competitive range of Ultrasonic, Eddy Current and MPI Equipment from a variety of manufacturers to best suit your purpose, requirement or

Ultrasonic Flaw Detectors and Thickness Meters:

We offer a wide range of ultrasonic flaw and thickness meters available to suit your purpose, including:

- Digital flaw detectors: all the leading makes available such as Sonatest, Proceq, Zetec, EddyFi, Olympus

Eddy Current Equipment

We offer a wide range of eddy current equipment to suit your purpose, including:

- UK & Eire Exclusive Distributor for IBG Eddy Current Technology
- Eddy current crack / flaw detectors: all the leading makes

Dye Penetrant Consumables

- Dye
- Developer

MPI Equipment & Consumables:

- Magnetic ink & contrast paint
- Electro-magnetic yokes
- Permanent magnets
- Test weights
- Magnetic flux indicators
- Gauss meters
- Settlement flasks

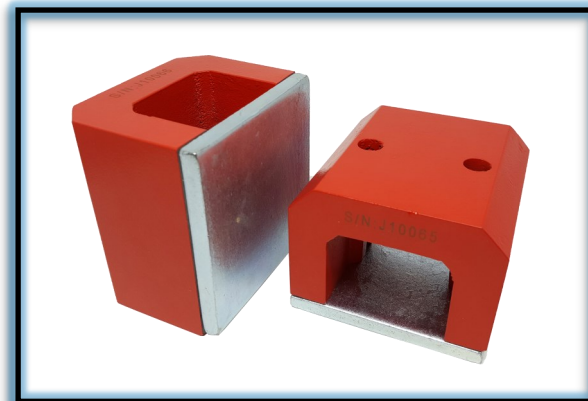
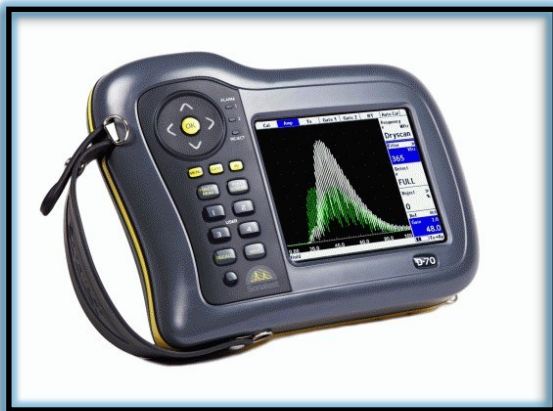

For prices and more options of NDT Equipment and Consumables contact our sales team where are happy to help.



Inspection, Testing & Asset-Integrity Solutions

Working in Partnership with

Introducing our latest transatlantic Partnership with **Sensor Networks Inc.** where GB Inspection Systems (GBIS) and Sensor Networks Inc. (SNI) will cooperate by cross selling each other's products with a focus on expanding their respective offerings.



GBIS will exclusively market and sell SNI's complete range of array transducers including the linear, matrix, dual-linear and high-temperature probes.

SNI will exclusively market and sell GBIS's TULA, Integral TOFD, LimboTOFD and European style Integral Wedge UT probes.

Phased Array Transducers and Accessories

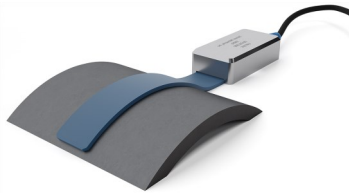

Sensor Networks Inc. manufacture and sells both industry standard and bespoke Phased Array Ultrasound Testing (PAUT) probes and wedges for the Non-destructive test industry, based in the USA.

These products are compatible with all brands of Phased array equipment and are interchangeable with other brands of probes and wedges.

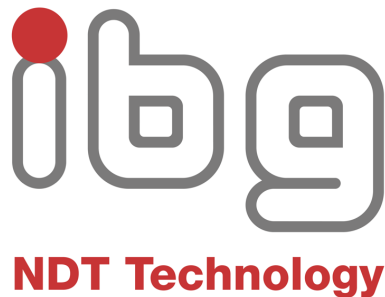

GB Inspection Systems Ltd are the exclusive UK distributor for **IBG NDT Systems.** IBG NDT Systems has 30 years experience designing and manufacturing state-of-the-art eddy current testers / instruments and systems.

True Eddy Current Technology. IBG's products are best categorised into three parts; Instrumentation which can be freestanding or integrated into systems, Coils & Probes and Automated systems and are produced at their manufacturing facilities in Germany, Switzerland and the USA.



Eddy Current Testing Systems

Global Partners

GB Inspection Systems has a global presence and a quality reputation for successfully supplying and servicing customers in many countries worldwide, with future expansion planned into countries not currently served. We use a number of global partners to distribute our products all over the world if you are interested in becoming one of our official distributors in your region please get in touch to find out more information.



GBIS News ...

GB Inspection Systems Ltd *E-commerce Website* and *integral-PALM™* Array launched in 2024

Contact our sales team either by Email: sales@gbinspection.com or Call +44 (0)121 351 5025

GB Inspection Systems Ltd



Made in Great Britain...
...Sold Worldwide

GB Inspection Systems Ltd.
22A Cobbett Road
Burntwood Business Park
Burntwood, Cannock
Staffordshire, WS7 3GL. UK

T +44 (0)121 351 5025
F +44 (0)1543 279619
E enquiries@gbinspection.com
W www.gbinspection.com
Company Registration Number 3021497